

CAPACITY	SYMBOL/ SERIAL NO.	CIRCUIT DIAGRAM
AC100-240V, 50/60Hz		
50W		

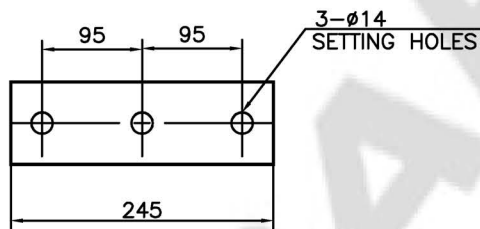

SETTING DIMENSION

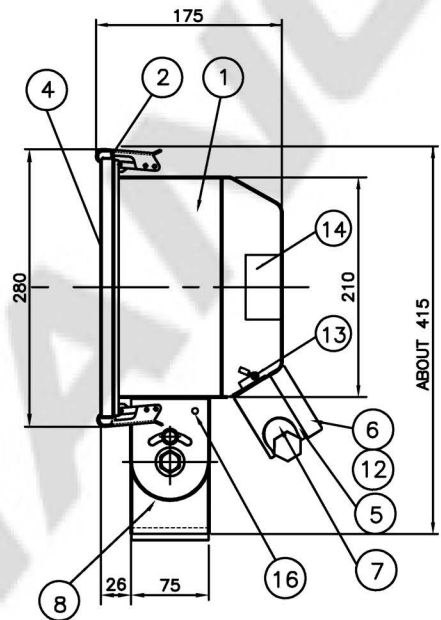
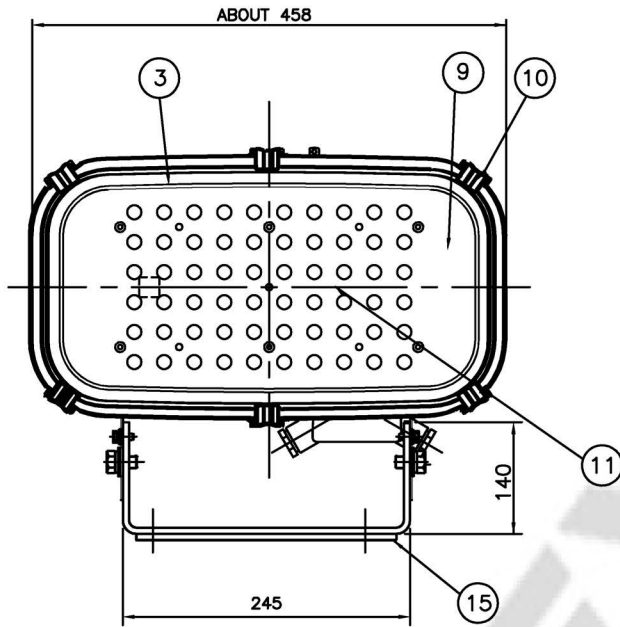
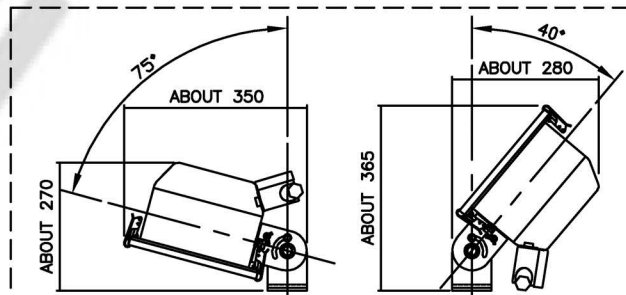

DOWN 75° DIMENSION

UP 40° DIMENSION

16	OUTSIDE EARTH BOLT	STAINLESS STEEL316	1	M5	8	ARM	STAINLESS STEEL316L	1	
15	ANTI-VIBRATION PACKING	C.R.	1	5mm	7	CABLE GLAND	BRASS	2	M24(φ14~17.5)
14	LED driver	-	1		6	TERMINAL BOX COVER	PBT	1	
13	INSIDE EARTH BOLT	STAINLESS STEEL316	1	M5	5	TERMINAL BOX	PBT	1	
12	TERMINAL BLOCK	-	1	3P	4	FRONT GLASS	GLASS	1	
11	LED module	-	1	6,000K	3	GLOBE PACKING	SILICONE	1	
10	LATCH	STAINLESS STEEL316L	6		2	GLOBE FRAME	STAINLESS STEEL316L	1	
9	SCREEN	ALUMINIUM	1		1	BODY	STAINLESS STEEL316L	1	
NO	NAME OF PARTS	MATERIAL	Q'TY	REMARKS	NO	NAME OF PARTS	MATERIAL	Q'TY	REMARKS

APPROVED	O. J. KWON	UNIT	MM
CHECKED		SCALE	N/S
DRAWING	B. I. KIM	COLOR	N-9.3
DATE	2019.03.03	IP	67

TITLE;
LED FLOOD LIGHT
FOR MARINE USE

	MODEL NO.	PF50L-550UWCFC60	WEIGHT	9.1 Kg
	DWG NO.	LR6530013	SHEET NO.	30